

## ENGLISH

# CX-Series

Productcode:	D4162	D4163	D4164	D4165	D4166
Productname:	CX-500	CX-900	CX-1500	CX-2100	CX-3000

## Table of contents

---

<b>Warning</b> .....	2
<b>Unpacking Instructions</b> .....	2
<b>Safety Instructions</b> .....	2
<b>Connection with the mains</b> .....	4
<b>Return Procedure</b> .....	4
<b>Claims</b> .....	4
<b>Functions &amp; Features</b> .....	5
<b>Operation</b> .....	5
Installation .....	5
Set Up and Operation .....	5
Mode Selection .....	5
<b>Main operation Key &amp; Functions</b> .....	6
Front Panel .....	6
Rear Panel .....	6
<b>Speakon output connection mode</b> .....	7
Stereo connection .....	7
Mono connection .....	8
Bridge connection .....	8
<b>Connection Cables</b> .....	9
<b>Specification</b> .....	10
<b>Troubleshooting</b> .....	10

## Warning



**FOR YOUR OWN SAFETY, PLEASE READ THIS USER MANUAL CAREFULLY  
BEFORE YOUR INITIAL START-UP!**



## Unpacking Instructions

Immediately upon receiving this product, carefully unpack the carton and check the contents to ensure that all parts are present and have been received in good condition. Notify the dealer immediately and retain packing material for inspection if any parts appear damaged from shipping or the carton itself shows signs of mishandling. Save the carton and all packing materials. In the event that a fixture must be returned to the factory, it is important that the fixture be returned in the original factory box and packing.

## Safety Instructions

Every person involved with the installation, operation and maintenance of this device has to:

- be qualified
- follow the instructions of this manual



**CAUTION! Be careful with your operations.  
With a dangerous voltage you can suffer  
a dangerous electric shock when touching the wires!**



Before your initial start-up, please make sure that there is no damage caused by transportation. Should there be any, consult your dealer and do not use the device.

To maintain perfect condition and to ensure a safe operation, it is absolutely necessary for the user to follow the safety instructions and warning notes written in this manual.

Please consider that damages caused by manual modifications to the device are not subject to warranty. This device contains no user-serviceable parts. Refer servicing to qualified technicians only.

### IMPORTANT!

The manufacturer will not accept liability for any resulting damages caused by the non-observance of this manual or any unauthorized modification to the system.

- Allow time to cool down, before cleaning or servicing.
- Always disconnect power from the mains, when system is not used. Only handle the power-cord by the plug. Never pull out the plug by tugging the power-cord.
- Always operate the unit with the AC ground wire connected to the electrical system ground.
- Avoid flames and do not put close to flammable liquids or gases.
- Avoid ground loops! Always be sure to connect the power amps and the mixing console to the same electrical circuit to ensure the same phase!
- Before changing the ground, always turn off your amplifier.
- Connecting amplifier outputs to oscilloscopes or other test equipment, while the amplifier is in bridged mode, may damage both the amplifier and test equipment.
- Do not connect this device to a dimmer pack.
- Do not drive the inputs with a signal level bigger, than required to drive the equipment to full output.
- Do not insert objects into air vents.
- Do not open the device and do not modify the device.
- Do not open this device. Risk: hazardous radiation exposure.

- Do not switch the system on and off in short intervals, as this would reduce the system's life.
- Don't put your equipment next to TV, radio, etc., because of interference or distortion.
- For replacement use fuses of same type and rating only.
- If device is dropped or struck, disconnect mains power supply immediately. Have a qualified engineer inspect for safety before operating.
- If the system has been exposed to drastic temperature fluctuation (e.g. after transportation), do not switch it on immediately. The arising condensation water might damage your system. Leave the system switched off until it has reached room temperature.
- If you connect other parts of the system, be careful of ground loops.
- If your Dap Audio device fails to work properly, discontinue use immediately. Pack the unit securely (preferably in the original packing material) and return it to your Dap Audio dealer for service.
- In system setup, the amplifier's output power must be 50%-100% more than the loaded loudspeakers rated power.
- In typical use, please set the volume at 0dB position.
- Make sure that the amplifier is turned down, before turning the power on or off. So you can avoid supersonic frequencies, which could damage your speakers.
- Make sure that the available voltage is not higher than stated on the rear panel.
- Make sure that the power-cord is never crimped or damaged. Check the device and the power-cord from time to time.
- Make sure that the signals into the mixer are balanced, otherwise hum could be created.
- Make sure you don't use the wrong kind of cables or defective cables.
- Make sure you use DI boxes to balance unbalanced signals; All incoming signals should be clear
- Never let the power-cord come into contact with other cables! Handle the power-cord and all connections with the mains with particular caution!
- Never remove warning or informative labels from the unit.
- Never use anything to cover the ground contact.
- Only use device indoor, avoid contact with water or other liquids.
- Please read this manual carefully and keep it for future reference. Remember that the amplifier has a better value on the market, if you save the carton and all packing materials.
- Please turn off the power switch, when changing the power cord or signal cable, or select the input mode switch.
- Prevent distortion! Make sure that all components connected to the device have sufficient power ratings. Otherwise distortion will be generated because the components are operated at their limits.
- Prevent distortion! Make sure that all components connected to the CX Amplifier have sufficient power ratings. Otherwise distortion will be generated because the components are operated at their limits.
- Repairs, servicing and electric connection must be carried out by a qualified technician.
- Sometimes, when you want to send one signal to more than one amplifier, you should use a signal distributor.
- The best way to avoid ground loops is connecting the electrical system ground to one central point ("star" system). In this case the mixer can act as a central point.
- This device falls under protection class I. Therefore it is essential to connect the yellow/green conductor to earth.
- WARRANTY: Till one year after date of purchase.



Disposing of this product should not be placed in municipal waste and should be separate collection.

## Connection with the mains

Connect the device to the mains with the power-plug.  
Always pay attention, that the right color cable is connected to the right place.

International	EU Cable	UK Cable	US Cable	Pin
L	BROWN	RED	YELLOW/COPPER	FASE
N	BLUE	BLACK	SILVER	NUL
	YELLOW/GREEN	GREEN	GREEN	EARTH

Make sure that the device is always connected properly to the earth!

### Improper installation can cause serious damage to people and property!



#### Return Procedure



Returned merchandise must be sent prepaid and in the original packing, call tags will not be issued. Package must be clearly labeled with a Return Authorization Number (RMA number). Products returned without an RMA number will be refused. Highlite will not accept the returned goods or any responsibility. Call Highlite 0031-455667723 or mail [offersales@highlite.nl](mailto:offersales@highlite.nl) and request an RMA prior to shipping the fixture. Be prepared to provide the model number, serial number and a brief description of the cause for the return. Be sure to properly pack fixture, any shipping damage resulting from inadequate packaging is the customer's responsibility. Highlite reserves the right to use its own discretion to repair or replace product(s). As a suggestion, proper UPS packing or double-boxing is always a safe method to use.

**Note: If you are given an RMA number, please include the following information on a piece of paper inside the box:**

- 1) Your name
- 2) Your address
- 3) Your phone number
- 4) A brief description of the symptoms

## Claims

The client has the obligation to check the delivered goods immediately upon delivery for any short-comings and/or visible defects, or perform this check after our announcement that the goods are at their disposal. Damage incurred in shipping is the responsibility of the shipper; therefore the damage must be reported to the carrier upon receipt of merchandise.

It is the customer's responsibility to notify and submit claims with the shipper in the event that a fixture is damaged due to shipping. Transportation damage has to be reported to us within one day after receipt of the delivery.

Any return shipment has to be made post-paid at all times. Return shipments must be accompanied with a letter defining the reason for return shipment. Non-prepaid return shipments will be refused, unless otherwise agreed in writing.

Complaints against us must be made known in writing or by fax within 10 working days after receipt of the invoice. After this period complaints will not be handled anymore.

Complaints will only then be considered if the client has so far complied with all parts of the agreement, regardless of the agreement of which the obligation is resulting.

## Functions & Features

---

- 2x Channel in and Link out.
- 2x Speakon out.
- Built-in Clip Limiter.
- Switchable entrance sensitivity: 0.775V and 1.4V.
- Bridge, parallel or stereo mode.
- Efficient heat-sink.
- Variable speed cooling fan.
- Front panel level gain control.
- Excellent audio signal performance.
- Very little harmonic distortion (THD), intermodulation distortion (SMPTE-IM), transient intermodulation distortion.

## Operation

---

### Installation

Remove all packing materials from the Vision. Check that all foam and plastic padding is removed. Screw the equipment into a 19" rack. Connect all cables.

Always disconnect from electric mains power supply before cleaning or servicing.

Damages caused by non-observance are not subject to warranty.

### Set Up and Operation

Before plugging the unit in, always make sure that the power supply matches the product specification voltage. Do not attempt to operate a 120V specification product on 240V power, or vice versa.

Install this device on a flat surface, not bending or curved.

Do not supply power before all components of the system are set up and connected properly.

### Mode Selection

The three-position, recessed Mode Select switch (located on the rear panel) configures the amplifier for either Stereo, Parallel or Bridged Mono Mode. Amplifiers are factory-configured for Stereo Mode.

# Main operation Key & Functions

## Front Panel

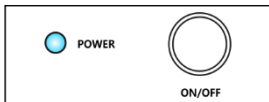
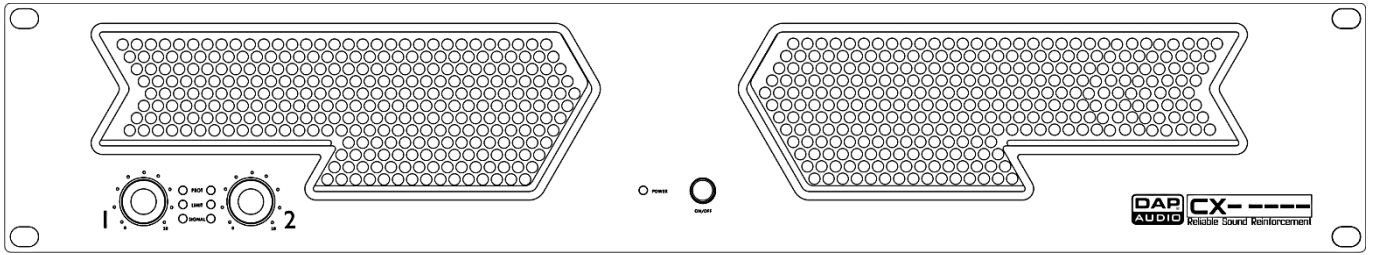

### Power switch

Use this switch to switch your power amplifier on.

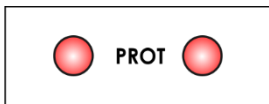

### Protection LED

When this indicator lights, the power amplifier is in protection mode. Switch off the device and find out what the problem is. The power amplifier is protected against overheat, overload, short circuit, DC.

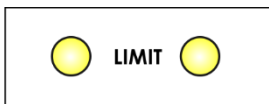

### Limit LED

Any illumination of the clip LED indicates distortion. In this case, check the signal of your source and turn down the input gain control. Please keep in mind that the power amplifier cannot correct any distortion.



### Signal LED

The illumination of the LED indicates a safe operation.

## Rear Panel

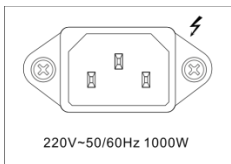
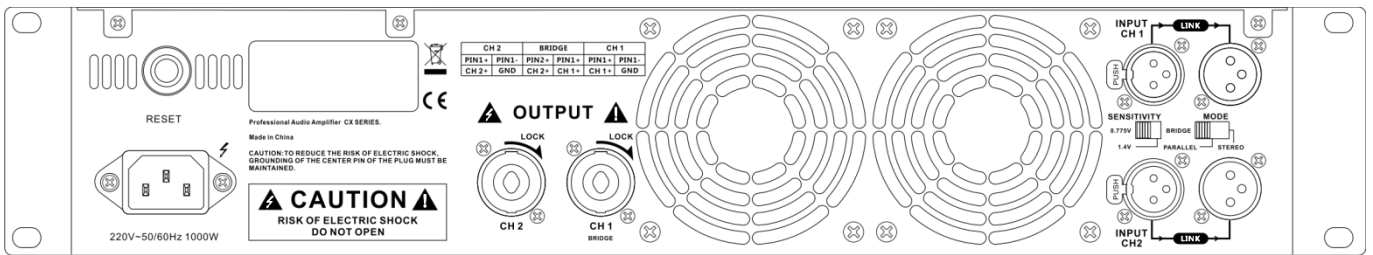

### Power connection

Plug the matching power cable (included) into this IEC power connector.

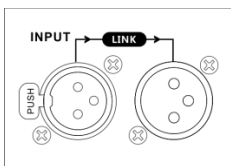

### Signal input

Connect your sound source XLR plugs. The link socket is used to connect to another device.



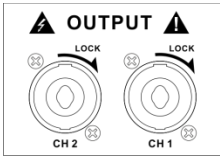

**Output connection**

Connect the amplifier to the speakers, using professional speaker cables with twist locking plugs.

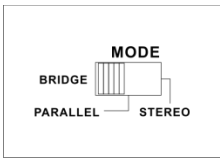

**Mode switch**

This switch is used to select the operating mode of the power amplifier.

Stereo: 2 inputs (channel 1 and 2) and 2 outputs are used.

Parallel: 1 input (channel 1) and 2 outputs are used.

Bridge: 1 input (channel 1) and 1 output are used.

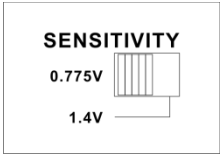

**Sensitivity mode**

This selector allows you to select the input sensitivity: 0.775V or 1.4V.

**Speakon output connection mode**

**Stereo connection**

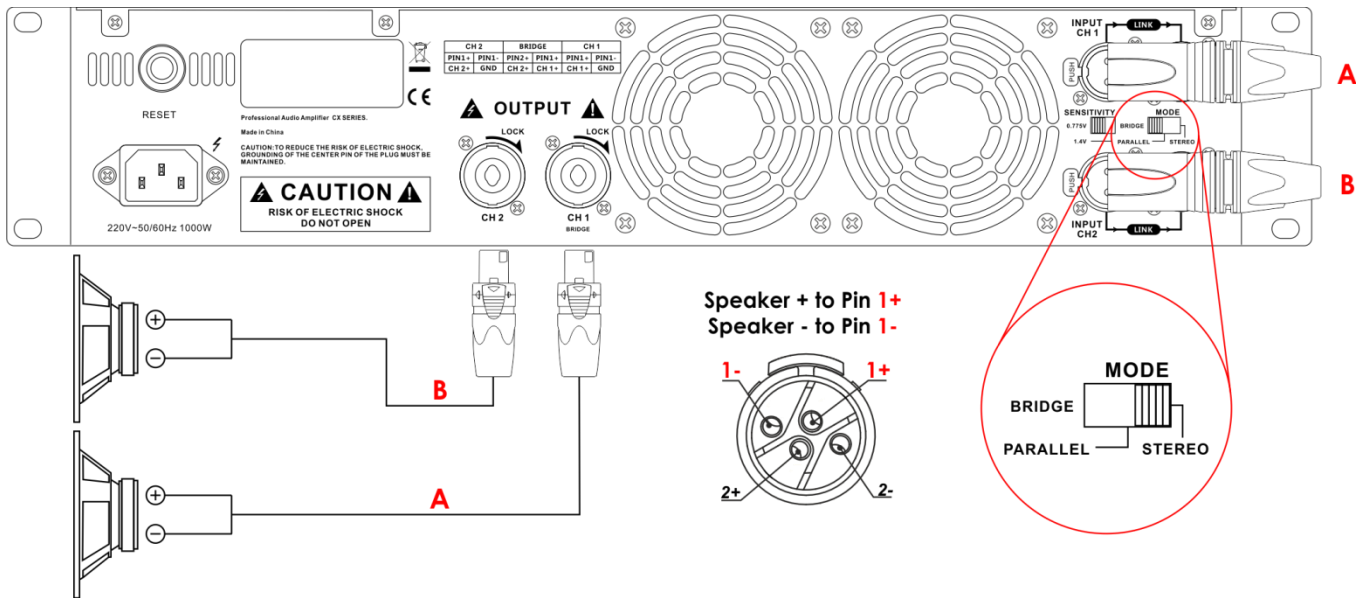



Parallel connection

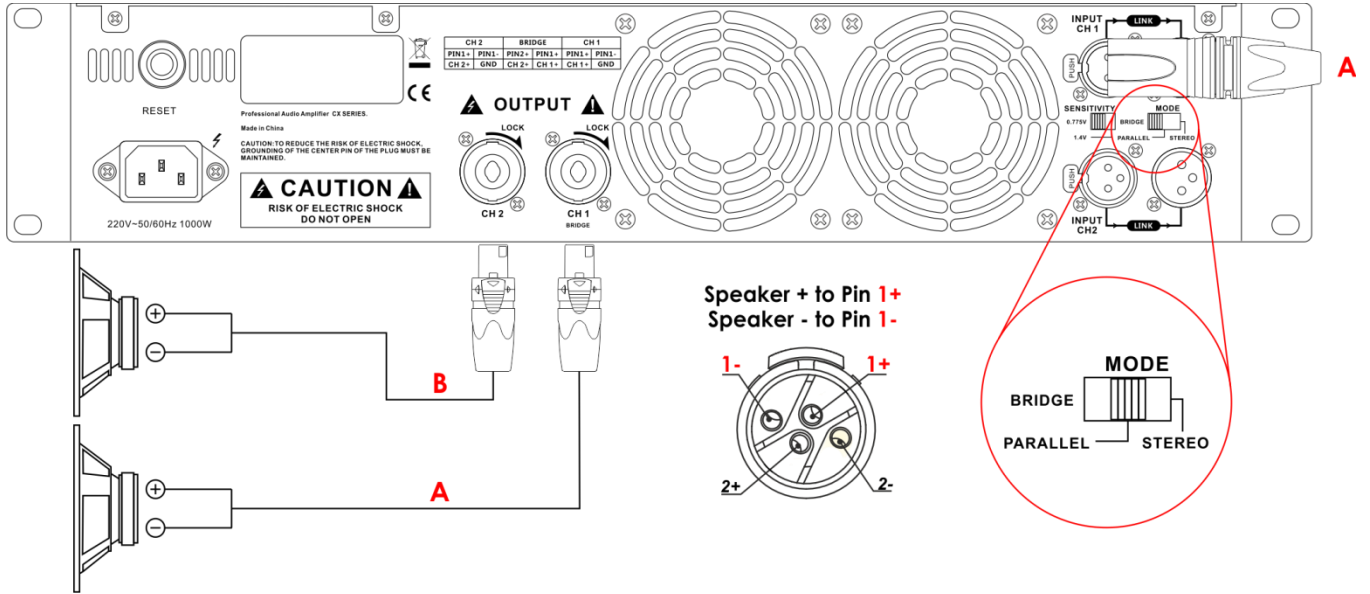

Bridge connection

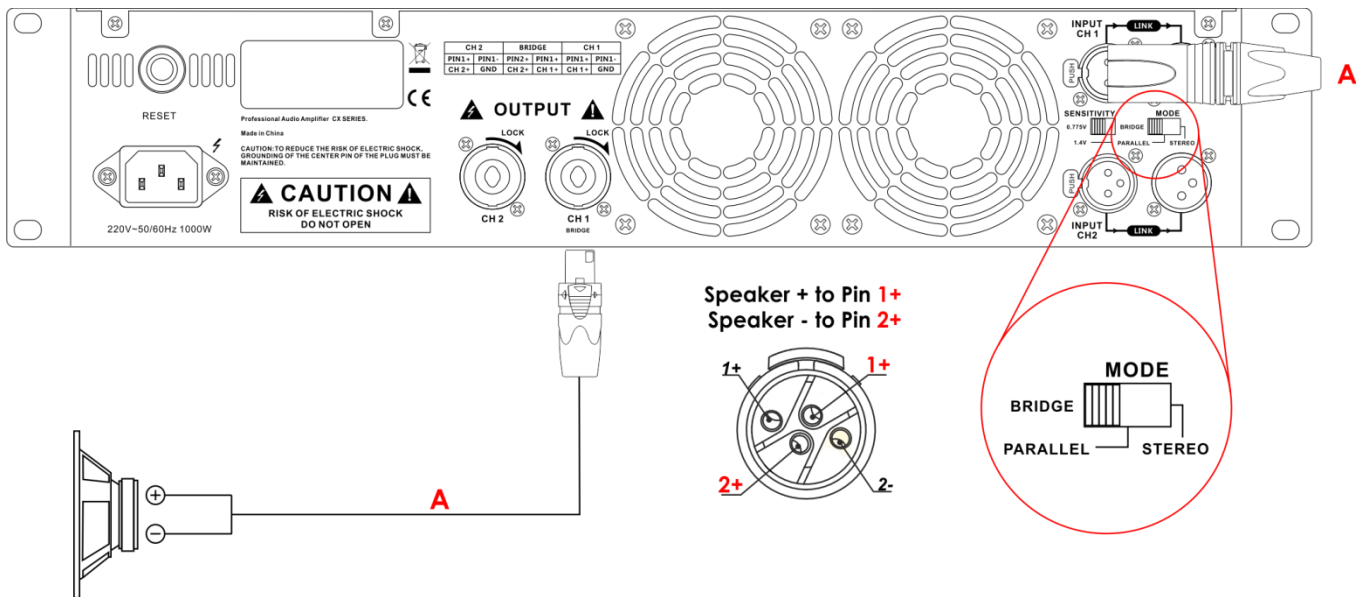

## Connection Cables

Take care of your cables, always holding them by the connectors and avoiding knots and twists when coiling them: This gives the advantage of increasing their life and reliability. Periodically check your cables. A great number of problems (faulty contacts, ground hum, discharges, etc.) are caused entirely by using unsuitable or faulty cables.

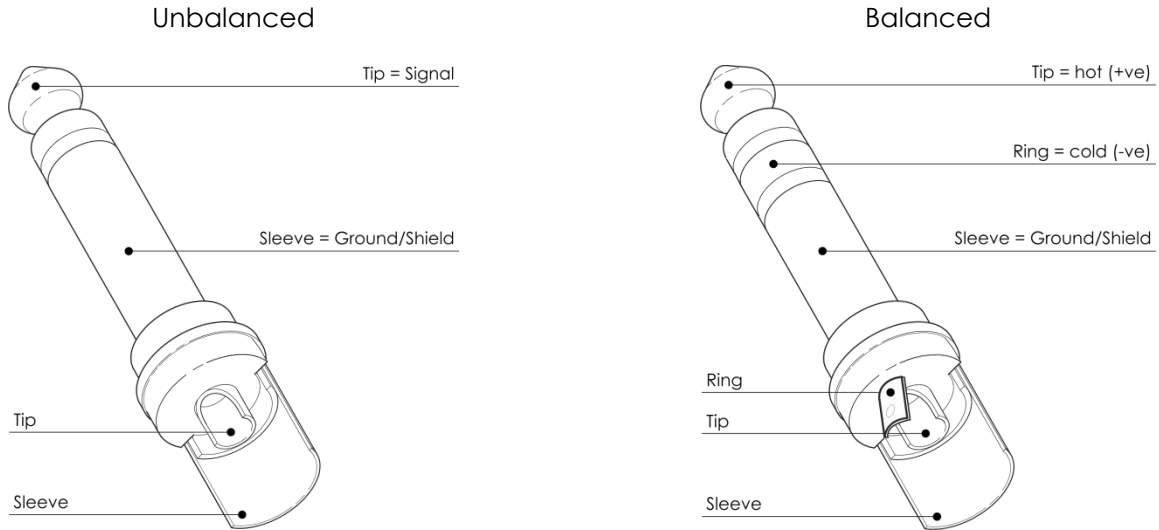

For these applications the unit provides 1/4" TRS and XLR connectors to easily interface with most professional audio devices. Follow the configuration examples below for your particular connection.

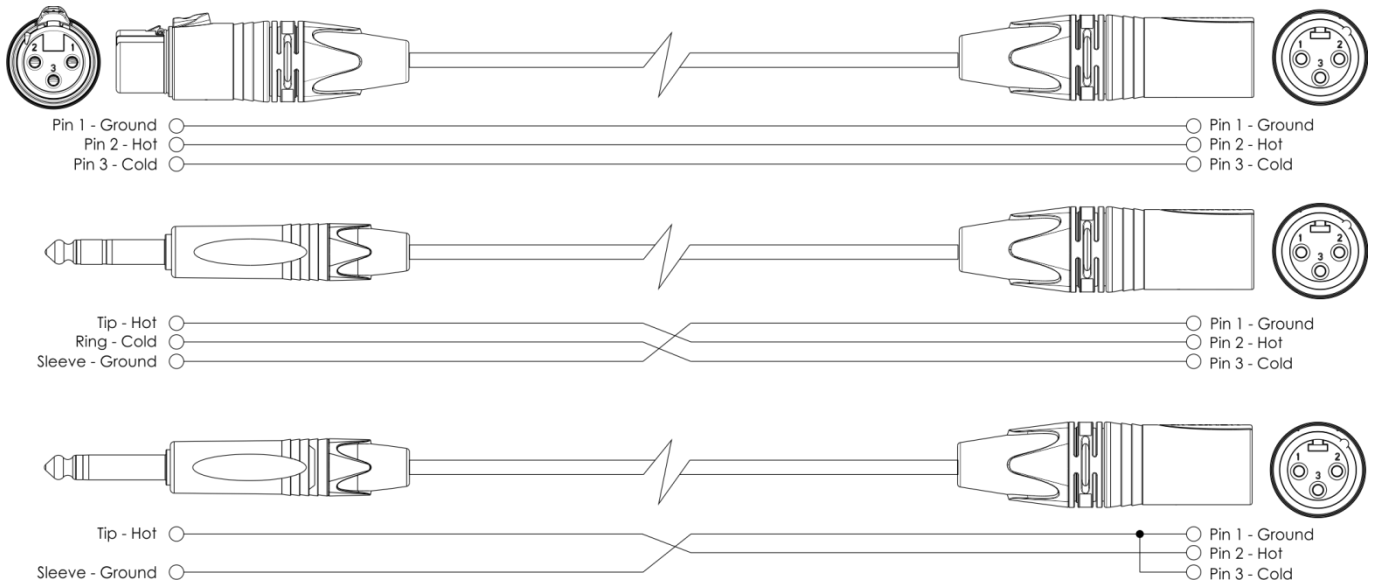

## Specification

Rated power /model	CX-500	CX-900	CX-1500	CX-2100	CX-3000
1kHz(HIA)with 0.5%THD 4Ω stereo(per channel)	200W	450W	750W	990W	1450W
8Ω stereo(per channel)	150W	350W	500W	700W	1250W
8Ω bridge mono	400W	900W	1500W	2000W	2900W
<b>Performance</b>					
Frequency Response(at 1 Watt)	20Hz - 20KHz,+ 0-1dB				
Total Harmonic Distortion(THD)	<0.5%, 20Hz - 20kHz				
Intermodulation Distortion 60Hz and 7KHz at 4:1 from full rated output to -30dB	= / <0.35%				
Slew Rate	>10V / us				
Voltage Gain	27dB	31dB	33dB	34dB	37dB
Damping Factor(8Ω)10Hz-400Hz	> 200				
Signal-to-Noise Ratio (below rated power,20Hz to 20kHz. A-weighted)	> 100dB				
Crosstalk(below rated power)					
At 1kHz	-75dB				
At 20kHz	-58dB				
Input Sensitivity for full rated power at 8Ω	0.775V or 1.4V				
Input impedance(nominal)					
Balanced	20K ohms				
Unbalanced	10k ohms				
<b>Construction</b>					
Protection	Protection against short circuits, no-load , on/off muting, RF interference.				
Ventilation	Flow-through ventilation from front to back.				
Cooling	Internal heat sinks with forced air . Fan cooled, speed regulated, thermal protection.				
Power cord specification	Plug: 10A , 250V Wire: 3x1.0mm <sup>2</sup>				
Chassis size (unit mm)	482x256x88				482x323x88
Net weight	10,1kg	12,7kg	13,5kg	14,5kg	19,5kg

## Troubleshooting

This troubleshooting guide is meant to help solve simple problems. If a problem occurs, carry out the steps below in sequence until a solution is found. Once the unit operates properly, do not carry out following steps.

1. If the device does not operate properly, unplug the device.
2. Check the fuse, power from the wall, all cables, etc.
3. If all of the above appears to be O.K., plug the unit in again.
4. If you are unable to determine the cause of the problem, do not open the device, as this may damage the unit and the warranty will become void.
5. Return the device to your Dap Audio dealer.



©2013 DAP Audio