

KPS-6000 series

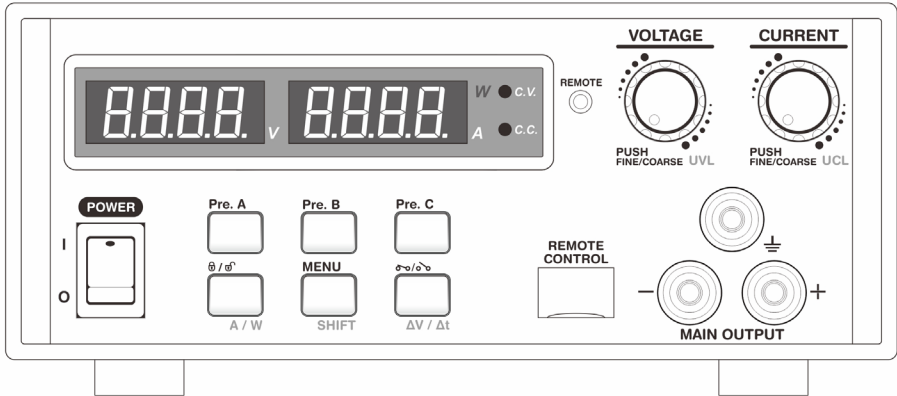

REMOTE PROGRAMMABLE POWER SUPPLY
WITH
ETHERNET NETWORK CONNECTIVITY
DC WAVE FORM GENERATOR
3 SELECTABLE VOLTAGE & CURRENT RANGES

USER MANUAL

Table of Contents

1.	PRECAUTIONS	3
1.1	Warning:	3
1.2	Caution:	3
1.3	Copy Right	3
1.4	Operation Environmental Condition:	4
2.	ACCESSORIES	4
3.	INTRODUCTION	4
4.	SPECIFICATIONS	5 - 9
5.	INDICATORS and CONTROLS	10 - 11
5.1	Back Panel	12
6.	OPERATION PROCEDURES	12
6.1	Adjusting Output Voltage and Current	12
6.2	Upper Voltage and Current Limit Adjustment	13
6.3	Select and Adjust 3 Preset Value of Voltage and Current	14
6.4	Output ON/OFF (Include Power up ON/OFF Setting)	14
6.5	Lock/Unlock of Front Panel	15
6.6	Watt-meter and Amp-meter Selection	15
6.7	Ramp UP/DOWN Generator	16 - 21
6.8	Factory Reset	21
6.9	Remote Control Interface Selection	22
6.10	Change Display Brightness	22
6.11	Voltage and Current setting Timeout Time	23
7.	MENU FLOW	24
8.	ANALOGUE REMOTE CONTROL MODE	25-28

1. PRECAUTIONS

Keep this manual in a safe place for quick reference at all times.

This manual contains important safety and operation instructions for correct use of the power supply. Read through the manual and pay special attention to the markings and labels of this unit and equipment to be connected.

Pay special attention to these two types of notices used in this manual

1.1 Warning:

Failure to observe this warning may cause injury to persons and damage to power supply or connected equipment.

1. Do not use this power supply near water.
2. Do not operate or touch this power supply with wet hands.
3. Do not open the casing of the power supply when it is connected to ac mains.
4. Refer all servicing to qualified service personnel only.
5. Before replacing the AC fuse find out and clear up the cause first.
6. Replace the AC fuse with the same type and rating as the original fuse.

1.2 Caution:

Failure to observe this warning may result in damage to equipment and Improper functioning of the power supply.

1. Use a grounded 3 pin AC source.
2. This unit is for indoor use only.
3. Do not operate or place this unit in a humid, dusty, in direct sunlight location or near any heat source.
4. Before plugging into local AC mains, check with the rating label at the back of the unit.
5. Do not block any ventilation openings of the unit.
6. This unit must be used within the specified rating, regular excessive continuous over loading may cause damage to the power supply.
7. The gauge size of input power cable must be at least 0.75mmsq and the total length of power cable must not exceed 3m.

1.3 Copy Right

All rights reserved. No part of this publication may be reproduced, or transmitted in any form or by any means without the written permission from Manson Engineering Industrial Ltd. Changes in the manual. Manson Engineering Industrial Ltd. has the right to update and change the content of this manual without any notice and obligation.

1.4 Operation Environmental Condition:

10-80% R.H.

Altitude up to 2000m

Installation category: CAT 2

Pollution degree: 2

Mains supply voltage fluctuation up to $\pm 10\%$ of the specified operating voltage.

2. ACCESSORIES

- a. AC Power cord
- b. CDROM include user manual, USB driver and PC control software
- c. Output cable with right angle safety plug and crocodile plug
- d. USB cable

3. INTRODUCTION

This KPS series of switching mode remote programming power supplies provide power test wave forms from the versatile 10 Steps generator which can simulate common test conditions for electronic devices. In addition to the supplied USB communication interface, an optional Ethernet interface card allows users to configure, control, or monitor basic power supply settings over the internet. KPS uses SCPI (Standard Commands of Programmable Instruments) syntax for easy system integration with test equipment. 4-digits display provide 10mV and 10mA resolution. Three user adjustable presets of voltage and current values can be saved for quick recall from the front panel buttons. User adjustable upper voltage and current limits make it extra safe for delicate and sensitive test piece. Output On-Off button and the Key Lock button allow safe and convenient operation. Analogue Remote Control of voltage, current and Output On-Off provide additional flexibility in the control of the power supply. It is ideal for laboratory, university, work shop, production, quality control and advanced DIY applications.

4. SPECIFICATIONS

Models	KPS-6100	KPS-6102	KPS-6104
OUTPUT			
Variable Output Voltage	1 - 18VDC	1 - 36VDC	1 - 60VDC
Variable Output Current	0 - 10A	0 - 5A	0 - 2.5A
VOLTAGE REGULATION			
Load (10-90% Rated Current)	≤50mV		
Line (180-264VAC Variation)	≤20mV		
CURRENT REGULATION			
Load (10-90% Rated Voltage)	≤100mA		
Line (180-264VAC Variation)	≤50mA		
RIPPLE & NOISE			
Ripple & Noise (r.m.s.) Voltage	≤5mV		
Ripple & Noise (peak-peak) Voltage	≤50mV	≤50mV	≤100mV
Switching Frequency	100 - 120KHz		
Tracking Over Voltage Protections	O/P ≤ 10V: set voltage +1V O/P > 10V: set voltage x100%		
METER TYPE & ACCURACY			
Voltage Meter	4 Digit LED Display ±(0.2% +3 counts)		
Current Meter	4 Digit LED Display ±(0.2% +3 counts)		
INPUT & EFFICIENCY			
Input Voltage	90 - 264V~ 50Hz		
Full Load Input Current (230VAC)	1.1A	1.1A	0.95A
Efficiency	≥82%	≥82%	≥82%
Power Factor Control	>95		
Cooling Method	Thermostatic Control Fan From Zero to Full Speed		
Protections	Overload, Short Circuit by Constant Current, Output Tracking Over Voltage, Over Temperature		
Standard Communication Port	USB 2.0		
Optional Interface	Ethernet, Factory or User Install		
Special Features	3 User defined V & I preset, Analogue Remote Control V, I and Output ON/OFF		
Preset Cycle Programming	10 steps Waveform Generator Max. Preset Cycle 999		
Approvals	CE EMC: EN 55011 ; LVD: EN 61010		
Dimensions (WxHxD)	200x90x247mm ; 7.9x3.5x9.7inch		
Weight	Approx. 2.4kgs ; 5.2lbs		

*All values are based on the Standard ambient Temperature 25°C and Pressure 0.1Mpa.

*SPECIFICATIONS ARE SUBJECT TO CHANGE WITHOUT PRIOR NOTICE

Models	KPS-6200	KPS-6202	KPS-6204
OUTPUT			
Variable Output Voltage	1 - 18VDC	1 - 36VDC	1 - 60VDC
Variable Output Current	0 - 20A	0 - 10A	0 - 5A
VOLTAGE REGULATION			
Load (10-90% Rated Current)	≤50mV		
Line (180-264VAC Variation)	≤20mV		
CURRENT REGULATION			
Load (10-90% Rated Voltage)	≤100mA		
Line (180-264VAC Variation)	≤50mA		
RIPPLE & NOISE			
Ripple & Noise (r.m.s.) Voltage	≤5mV		
Ripple & Noise (peak-peak) Voltage	≤50mV	≤50mV	≤100mV
Switching Frequency	100 - 120KHz		
Tracking Over Voltage Protections	O/P ≤ 10V: set voltage +1V O/P > 10V: set voltage x100%		
METER TYPE & ACCURACY			
Voltage Meter	4 Digit LED Display ±(0.2% +3 counts)		
Current Meter	4 Digit LED Display ±(0.2% +3 counts)		
INPUT & EFFICIENCY			
Input Voltage	90 - 264V~ 50Hz		
Full Load Input Current (230VAC)	2.2A	2.2A	1.8A
Efficiency	≥83%	≥84%	≥85%
Power Factor Control	>95		
Cooling Method	Thermostatic Control Fan From Zero to Full Speed		
Protections	Overload, Short Circuit by Constant Current, Output Tracking Over Voltage, Over Temperature		
Standard Communication Port	USB 2.0		
Optional Interface	Ethernet, Factory or User Install		
Special Features	3 User defined V & I preset, Analogue Remote Control V, I and Output ON/OFF		
Preset Cycle Programming	10 steps Waveform Generator Max. Preset Cycle 999		
Approvals	CE EMC: EN 55011 ; LVD: EN 61010		
Dimensions (WxHxD)	200x90x247mm ; 7.9x3.5x9.7inch		
Weight	Approx. 2.4kgs ; 5.2lbs		

*All values are based on the Standard ambient Temperature 25°C and Pressure 0.1Mpa.

*SPECIFICATIONS ARE SUBJECT TO CHANGE WITHOUT PRIOR NOTICE

Models	KPS-6300	KPS-6302	KPS-6304
OUTPUT			
Variable Output Voltage	1 - 16VDC	1 - 32VDC	1 - 60VDC
Variable Output Current	0 - 30A	0 - 15A	0 - 8A
VOLTAGE REGULATION			
Load (10-90% Rated Current)	≤50mV		
Line (180-264VAC Variation)	≤20mV		
CURRENT REGULATION			
Load (10-90% Rated Voltage)	≤150mA	≤100mA	≤100mA
Line (180-264VAC Variation)	≤50mA		
RIPPLE & NOISE			
Ripple & Noise (r.m.s.) Voltage	≤5mV		
Ripple & Noise (peak-peak) Voltage	≤50mV	≤50mV	≤100mV
Switching Frequency	100 - 120KHz		
Tracking Over Voltage Protections	O/P ≤ 10V: set voltage +1V O/P > 10V: set voltage x100%		
METER TYPE & ACCURACY			
Voltage Meter	4 Digit LED Display ±(0.2% +3 counts)		
Current Meter	4 Digit LED Display ±(0.2% +3 counts)		
INPUT & EFFICIENCY			
Input Voltage	180 - 264V~ 50Hz (or on request)		
Full Load Input Current (230VAC)	2.6A	2.6A	2.6A
Efficiency	≥84%	≥85%	≥85%
Power Factor Control	>95		
Cooling Method	Thermostatic Control Fan From Zero to Full Speed		
Protections	Overload, Short Circuit by Constant Current, Output Tracking Over Voltage, Over Temperature		
Standard Communication Port	USB 2.0		
Optional Interface	Ethernet, Factory or User Install		
Special Features	3 User defined V & I preset, Analogue Remote Control V, I and Output ON/OFF		
Preset Cycle Programming	10 steps Waveform Generator Max. Preset Cycle 999		
Approvals	CE EMC: EN 55011 ; LVD: EN 61010		
Dimensions (WxHxD)	200x90x292mm ; 7.9x3.5x11.5inch		
Weight	Approx. 3kgs ; 6.6lbs		

*All values are based on the Standard ambient Temperature 25°C and Pressure 0.1Mpa.

*SPECIFICATIONS ARE SUBJECT TO CHANGE WITHOUT PRIOR NOTICE

Models	KPS-6400	KPS-6402	KPS-6404
OUTPUT			
Variable Output Voltage	1 - 16VDC	1 - 32VDC	1 - 60VDC
Variable Output Current	0 - 40A	0 - 20A	0 - 10A
VOLTAGE REGULATION			
Load (10-90% Rated Current)	≤50mV		
Line (180-264VAC Variation)	≤20mV		
CURRENT REGULATION			
Load (10-90% Rated Voltage)	≤150mA	≤100mA	≤100mA
Line (180-264VAC Variation)	≤50mA		
RIPPLE & NOISE			
Ripple & Noise (r.m.s.) Voltage	≤5mV		
Ripple & Noise (peak-peak) Voltage	≤50mV	≤50mV	≤100mV
Switching Frequency	65 - 85KHz		
Tracking Over Voltage Protections	O/P ≤ 10V: set voltage +1V O/P > 10V: set voltage x100%		
METER TYPE & ACCURACY			
Voltage Meter	4 Digit LED Display ±(0.2% +3 counts)		
Current Meter	4 Digit LED Display ±(0.2% +3 counts)		
INPUT & EFFICIENCY			
Input Voltage	180 - 264V~ 50Hz (or on request)		
Full Load Input Current (230VAC)	3.5A	3.5A	3.2A
Efficiency	≥84%	≥85%	≥87%
Power Factor Control	>95		
Cooling Method	Thermostatic Control Fan From Zero to Full Speed		
Protections	Overload, Short Circuit by Constant Current, Output Tracking Over Voltage, Over Temperature		
Standard Communication Port	USB 2.0		
Optional Interface	Ethernet, Factory or User Install		
Special Features	3 User defined V & I preset, Analogue Remote Control V, I and Output ON/OFF		
Preset Cycle Programming	10 steps Waveform Generator Max. Preset Cycle 999		
Approvals	CE EMC: EN 55011 ; LVD: EN 61010		
Dimensions (WxHxD)	200x90x292mm ; 7.9x3.5x11.5inch		
Weight	Approx. 3kgs ; 6.6lbs		

*All values are based on the Standard ambient Temperature 25°C and Pressure 0.1Mpa.

*SPECIFICATIONS ARE SUBJECT TO CHANGE WITHOUT PRIOR NOTICE

Models	KPS-6600	KPS-6602	KPS-6604
OUTPUT			
Variable Output Voltage	1 - 16VDC	1 - 32VDC	1 - 60VDC
Variable Output Current	0 - 60A	0 - 30A	0 - 15A
VOLTAGE REGULATION			
Load (10-90% Rated Current)	≤50mV		
Line (180-264VAC Variation)	≤20mV		
CURRENT REGULATION			
Load (10-90% Rated Voltage)	≤200mA	≤150mA	≤100mA
Line (180-264VAC Variation)	≤50mA		
RIPPLE & NOISE			
Ripple & Noise (r.m.s.) Voltage	≤5mV		
Ripple & Noise (peak-peak) Voltage	≤50mV	≤50mV	≤100mV
Switching Frequency	65 - 85KHz		
Tracking Over Voltage Protections	O/P ≤ 10V: set voltage +1V O/P > 10V: set voltage x100%		
METER TYPE & ACCURACY			
Voltage Meter	4 Digit LED Display ±(0.2% +3 counts)		
Current Meter	4 Digit LED Display ±(0.2% +3 counts)		
INPUT & EFFICIENCY			
Input Voltage	180 - 264V~ 50Hz (or on request)		
Full Load Input Current (230VAC)	5.0A	4.9A	4.5A
Efficiency	≥86.5%	≥89%	≥87%
Power Factor Control	>95		
Cooling Method	Thermostatic Control Fan From Zero to Full Speed		
Protections	Overload, Short Circuit by Constant Current, Output Tracking Over Voltage, Over Temperature		
Standard Communication Port	USB 2.0		
Optional Interface	Ethernet, Factory or User Install		
Special Features	3 User defined V & I preset, Analogue Remote Control V, I and Output ON/OFF		
Preset Cycle Programming	10 steps Waveform Generator Max. Preset Cycle 999		
Approvals	CE EMC: EN 55011 ; LVD: EN 61010		
Dimensions (WxHxD)	200x90x332mm ; 7.9x3.5x13inch		
Weight	Approx. 3kgs ; 6.6lbs		

*All values are based on the Standard ambient Temperature 25°C and Pressure 0.1Mpa.

*SPECIFICATIONS ARE SUBJECT TO CHANGE WITHOUT PRIOR NOTICE

5. INDICATORS and CONTROLS

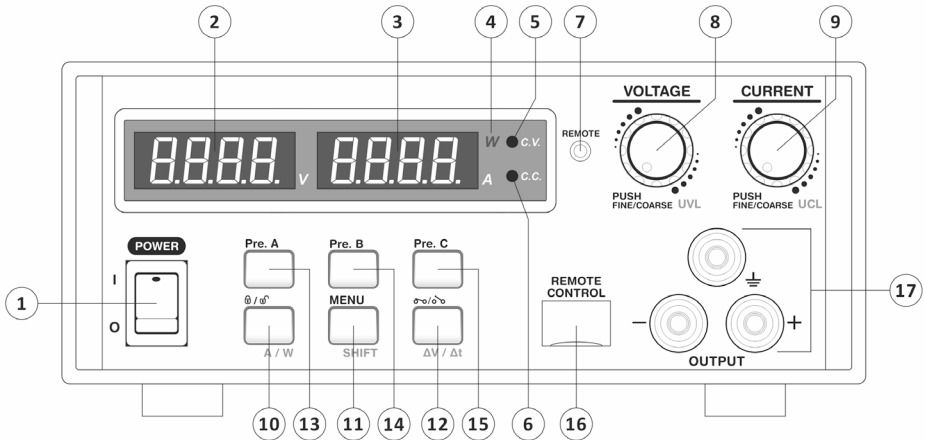

1. Main Power Switch

The main power of power supply. Switch to I position to power on the power supply and switch to O position to power off the power supply.

2. Volt. Meter

3. Amp. Meter

4. Power Indicator

Indicate the right part 4 digits LED is watt-meter. The display is showing actual output Power value.

5. Constant Voltage Mode Indicator

Indicate the Power Supply is working in Constant Voltage mode. The output voltage of power supply is remains constant at the set voltage in this mode. The power supply will be working in this mode while the loading current is least than the set current.

6. Constant Current Mode Indicator

Indicate the Power Supply is working in Constant Current mode. The output current of power supply is remains constant at the set current provided that the loading is sufficient to draw current equal to or larger than set current.

7. Remote Control Indicator

Indicate the Power Supply is under remote control. Whenever you connection power supply using control software through USB or Ethernet or Analog remote control. This LED will be ON.

8. Voltage Adjust Knob

This knob is for output Voltage setting and UVL adjustment

9. Current Adjust Knob

This knob is for output Current and UCL adjustment

10. Lock & A/W Selection Button

Press this button to LOCK and UNLOCK the keypad and knobs. This button ON indicate the keypad and knobs are being locked. When using with SHIFT key on, it is used to select the right hand side display operate as watt-meter or amp-meter.

11. MENU & SHIFT Button

Long press this button to enter menu mode. The display show dVdt indicate the power supply is in menu mode.

Short press this button and it light on to indicate shift key ready. Then the second function of related buttons will be used. The second function of buttons include $\Delta V/\Delta t$, A/W, UVL, UCL.

12. Output ON/ OFF & Ramp UP/ DOWN Program Running Button

Press this button to switch the output ON and OFF. This button ON indicate the output is ON. When using with SHIFT key on, it will start ramp up/ ramp down program (Refer to Ramp Up/ Ramp Down generator section)

13. Preset A Button

Indicate Preset A is selected, the output voltage and current will set preset A value.

14. Preset B Button

Indicate Preset B is selected, the output voltage and current will set preset B value.

15. Preset C Button

Indicate Preset C is selected, the output voltage and current will set preset C value.

16. USB Remote Control Port

17. Output Terminal

5.1 Back Panel

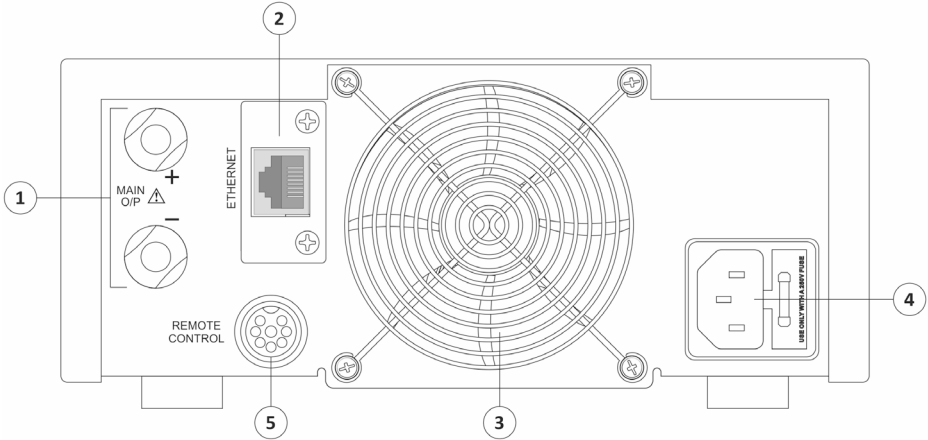

1. **Main Output Terminal (only for 6300, 6400, 6600, 6602)**
2. **Optional Ethernet Card (Manson model AEN-8102)**
3. **Cooling Fan**
4. **AC Input Socket**
5. **Analogue Remote Control Port (More details please refer to section 8)**

6. OPERATION PROCEDURES

6.1 Adjusting Output Voltage and Current

Adjust Output Voltage



- Rotate Voltage Knob clockwise to INCREASE output voltage.
 - Rotate Voltage Knob anti-clockwise to REDUCE output voltage.
- Press Voltage knob to switch between COARSE and FINE adjustment. When press the knob the digit will be high-lighted for adjust.

Adjust Output Current



- Rotate Current Knob clockwise to increase output current.
 - Rotate Current Knob anti-clockwise to reduce output current.
- Press Current knob to switch between COARSE and FINE adjustment. When press the knob the digit will be high-lighted for adjust.

6.2 Upper Voltage and Current Limit Adjustment

Upper Voltage Limit (UVL)

The Upper Voltage Limit is feature to let user to set maximum value for voltage adjustment. This feature can help to prevent accidentally adjust to very high output voltage to cause damage on object under testing.

During increasing output voltage and hit the UVL, the display will show you alert as follow;



Adjust Upper Voltage Limit

- The second function of Voltage knob is for UVL adjustment.

- Press  and the button will ON.
- Then press Voltage knob. The display will show as follow;



- Rotate Voltage knob to adjust the value.
- Press  to confirm setting. If the new UVL value is lower than set voltage, it will show UVL Error alert.

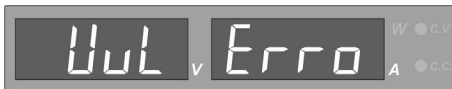

Just reduce the set Voltage to lower than the UVL value. Then the UVL Error will OFF.

Upper Current Limit (UCL)

The Upper Current Limit is feature to let user to set maximum value for current adjustment. This feature can help to prevent accidentally to set load current too high to damage on object under test.

During increasing output current and hit the UCL, the display will show you alert as follow;

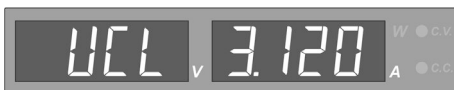

Adjust Upper Current Limit:

- The second function of Current knob is for UCL adjustment.

- Press  and the button will ON.
- Then press Current knob. The display will show as follow;



- Rotate Current knob to adjust the value.
- Press  to confirm setting. If the new UCL value is lower than set



current, it will show UCL Error alert.

Just reduce the set current to lower than the UCL value. Then the UCL Error will OFF.

6.3 Select and adjust 3 Preset Value of Voltage and Current

This power supply has 3 preset program of Voltage and Current value for quick recall to use.

To selection preset program, just press Pre1/ Pre2/ Pre3.

To adjust value of preset program. After preset program is selected, use Voltage and Current knob to adjust value for that preset program. The setting will be saved automatically.

The value can be reset to factory default in menu. (See **Factory Reset** Section).

6.4 Output ON/OFF (Include power up ON/OFF setting)

The power has feature to switch output ON/OFF by pressing  button.





The LED will ON when the output is ON. The display will show the actual output value of voltage and current/ watt.

Change Power Up output ON/OFF setting

The power up output ON/OFF status can be configured according to usage requirement.

The default setting is output OFF when system power up. It has option to set SAME AS LAST STATUS. That means the output ON/OFF status will same as status before power off.

Steps to change setting;

- Step 1 Press and hold  to enter menu.
- Step 2 Rotate Volt. knob to select PU menu. The display show
- 
- Step 3 Press Volt. knob to enter PU setting. The display show
- 
- Step 4 Rotate Curr. knob to change setting to
- 
- The output is set to as same as last status.
- Step 5 Press volt. knob to confirm.
- Step 6 Press  to exit menu.



6.5 Lock/Unlock of Front Panel

In case the front panel is locked, only the  has function. Other buttons and knobs are being locked. The front panel will be locked in two conditions.

- Manually press  to LOCK the front panel.
- The unit is under remote control by PC through USB or Ethernet or analog remote control.

6.6 Watt-meter and Amp-meter selection

The lower part of 4 digit display can use as Watt-meter or Amp-meter. It can switch anytime.

- Press  and the button will ON.
- Press  to switch between Watt-meter and Amp-meter. W and A LED will ON alternatively.

6.7 Ramp Up/ Ramp Down Generator

The KPS series has function to generate waveform with ramp up and ramp down. It allow to set 10 steps of wave.

The Ramp Up/Ramp Down function can be done by both Remote Programming via USB interface to your PC and on panel manual programming. It is recommended to use Remote Programming for faster set up with visual wave forms and easy retrievals.

Steps to setup ramp up/ ramp down wave;

- Step 1 Press and hold  to enter menu.
- Step 2 Rotate Volt. knob to select dvdt menu. The display show







- Step 3 Press Volt. knob to enter dvdt setting. The display show



- Step 4 Rotate Volt. knob to set items
- Step 5 Rotate Curr. knob to change value of set items.

The below table show the available set items and value range for dvdt menu.

Set item	Description	Value range
	Number of steps to be use for wave form generation. Must start from step 1.	2-10
	Number of cycle to run for wave form	0 to 999 0 means run forever
	Step 1 to Step 10 Voltage setting (in V)	0 to 36V
	Step 1 to Step 10 Current setting (in A)	0 to Max Current
	Step 1 to Step 10 run time length (in S)	0 to 600s

- Step 6 Press Volt. knob to back to menu mode.

- Step 7 Press  to confirm and exit menu.

Steps to Run ramp up/ ramp down wave;

Step 1 Press  to switch on output.

Step 2 Press  and the button will on.







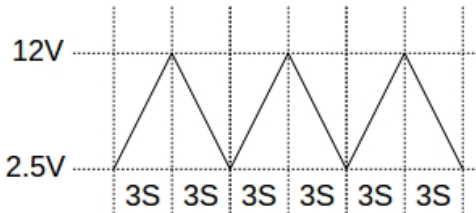

Step 3 Press  to run dvdt program.

Examples:

Example 1 Triangular Waveform.











Setting Value:

Set item	Value	Explanation
	2	Set 2 steps to run. Step 1 and Step 2
	3	Run 3 cycle only
	2.5	Set Step 1 voltage to 2.5V
	5	Set Step 1 current to 5A
	3	Set Step 1 run time to 3s (Ramp UP from step 1 voltage to step 2 voltage in 3s)
	12	Set Step 2 voltage to 12V
	10	Set Step 2 current to 10A
	3	Set Step 2 run time to 3s (Ramp DOWN from step 2 voltage to step 1 voltage in 3s)

Example 2 Saw-tooth Waveform.



Setting Value:

Set item	Value	Explanation
	2	Set 2 steps to run. Step 1 and Step 2
	6	Run 6 cycle only
	2.5	Set Step 1 voltage to 2.5V
	5	Set Step 1 current to 5A
	3	Set Step 1 run time to 3s (Ramp UP from step 1 voltage to step 2 voltage in 3s)
	12	Set Step 2 voltage to 12V
	10	Set Step 2 current to 10A
	0	Set Step 2 run time to 0s (Edge DOWN from step 2 voltage to step 1 voltage in 0s)

Example 3 Rectangular Waveform

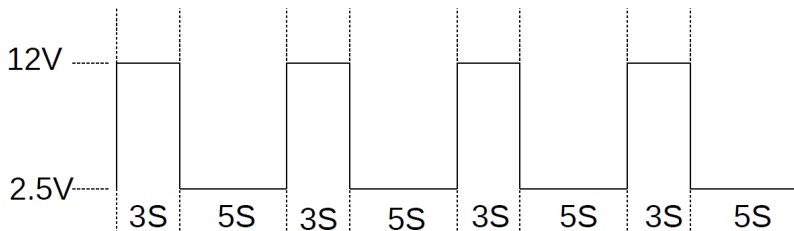

Setting Value:





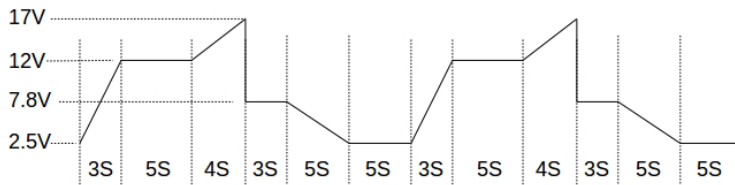

Set item	Value	Explanation
	4	Set 4 steps to run. From Step 1 and Step 4
	4	Run 4 cycle only
	2.5	Set Step 1 voltage to 2.5V
	5	Set Step 1 current to 5A
	0	Set Step 1 run time to 0s (Edge UP from step 1 voltage to step 2 voltage in 0s)
	12	Set Step 2 voltage to 12V
	10	Set Step 2 current to 10A
	3	Set Step 2 run time to 3s (Keep at 12V by 3s, since step 2 voltage = step 3 voltage)
	12	Set Step 3 voltage to 12V
	7	Set Step 3 current to 7A
	0	Set Step 3 run time to 0s (Edge DOWN from step 3 voltage to step 4 voltage in 0s)
	2.5	Set Step 4 voltage to 2.5V
	6.5	Set Step 4 current to 6.5A
	5	Set Step 4 run time to 5s (Keep at 2.5V by 5s, since step 4 voltage = step 1 voltage)

Example 4 Irregular Waveform



Setting Value:

Set item	Value	Explanation
rUNP	7	Set 7 steps to run. Step 1 and Step 7
rUNC	0	Run forever
PO1v	2.5	Set Step 1 voltage to 2.5V
PO1A	5	Set Step 1 current 5A
PO1t	3	Set Step 1 run time to 3s (Ramp UP from step 1 voltage to step 2 voltage in 3s)
PO2v	12	Set Step 2 voltage to 12V
PO2A	10	Set Step 2 current to 10A
PO2t	5	Set Step 2 run time to 5s (Keep at 12V by 5s, since step 2 voltage = step 3 voltage)
PO3v	12	Set Step 3 voltage to 12V
PO3A	7	Set Step 3 current to 7A
PO3t	4	Set Step 3 run time to 4s (Ramp UP from step 3 voltage to step 4 voltage in 4s)
PO4v	17	Set Step 4 voltage to 17V
PO4A	6.5	Set Step 4 current to 6.5A
PO4t	0	Set Step 4 run time to 0s (Edge DOWN from step 4 voltage to step 5 voltage in 0s)
PO5v	7.8	Set Step 5 voltage to 7.8V
PO5A	9	Set Step 5 current to 9A
PO5t	3	Set Step 5 run time to 3s (Keep at 7.8V by 3s step 5 voltage = step 6 voltage)

	7.8	Set Step 6 voltage to 7.8V
	4	Set Step 6 current to 4A
	5	Set Step 6 run time to 5s (Ramp DOWN from step 6 voltage to step 7 voltage in 5s)
	2.5	Set Step 7 voltage to 2.5V
	9.9	Set Step 7 current to 9.9A
	5	Set Step 7 run time to 5s (Keep at 2.5V by 5s, since step 7 voltage = step 1 voltage)

6.8 Factory Reset

The Factory reset feature is reset the Preset program, UVL, UCL to factory default setting.

Steps for Factory reset;

- Step 1 Press and hold  button to enter setting menu.
- Step 2 Rotate VOLT. knob to select factory reset menu. The display shows



- Step 3 Press VOLT. knob to enter address menu. The display shows







- Step 4 Rotate CURR knob to change from No to YES.
- Step 5 Press CURR. knob to reset unit.
The power will reset immediately.

6.9 Remote Control Interface Selection

The KPS bundles with USB port for remote control. The Ethernet Card is optional accessory. The remote control interface can be selected in menu.

Steps for Remote Control interface selection;





- Step 1 Press and hold  button to enter setting menu.
- Step 2 Rotate VOLT. knob to select UNS menu. The display shows
- 
- Step 3 Press VOLT. knob to enter UNS menu. The display shows
- 
- Step 4 Rotate CURR knob to change from USB to LAN for Ethernet interface.
- Step 5 Press VOLT knob to return to menu mode.
- Step 6 Press  to exit menu.

Please reference to software user manual for detail operation of PC control software.

6.10 Change Display Brightness

The KPS display has 8 levels of brightness for user to select.

Steps for changing display brightness;

- Step 1 Press and hold  button to enter setting menu.
- Step 2 Rotate VOLT knob to select diSP menu. The display shows
- 
- Step 3 Rotate VOLT knob to enter display setting. The display shows
- 
- Step 4 Rotate CURR knob to change the brightness setting. The setting value can be set from 0 to 7 means the less brightness.
- 
- Step 5 Press VOLT knob to confirm.
- Step 6 Press  to exit menu.

6.11 Voltage and Current setting Timeout time

This timeout time is the time that the display auto exit from voltage and current setting and return to normal display. The timeout time can be set from 1s to 30s.

Steps for changing timeout time;

Step 1 Press and hold  button to enter setting menu.

Step 2 Rotate VOLT knob to select tOUT menu. The display shows



Step 3 Rotate VOLT knob to enter tOUT setting. The display shows

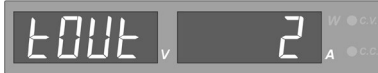

Step 4 Rotate CURR knob to change timeout setting. The setting value can be set from 1 to 30.

Step 5 Press VOLT knob to confirm.



Step 6 Press  to exit menu.

7. MENU FLOW

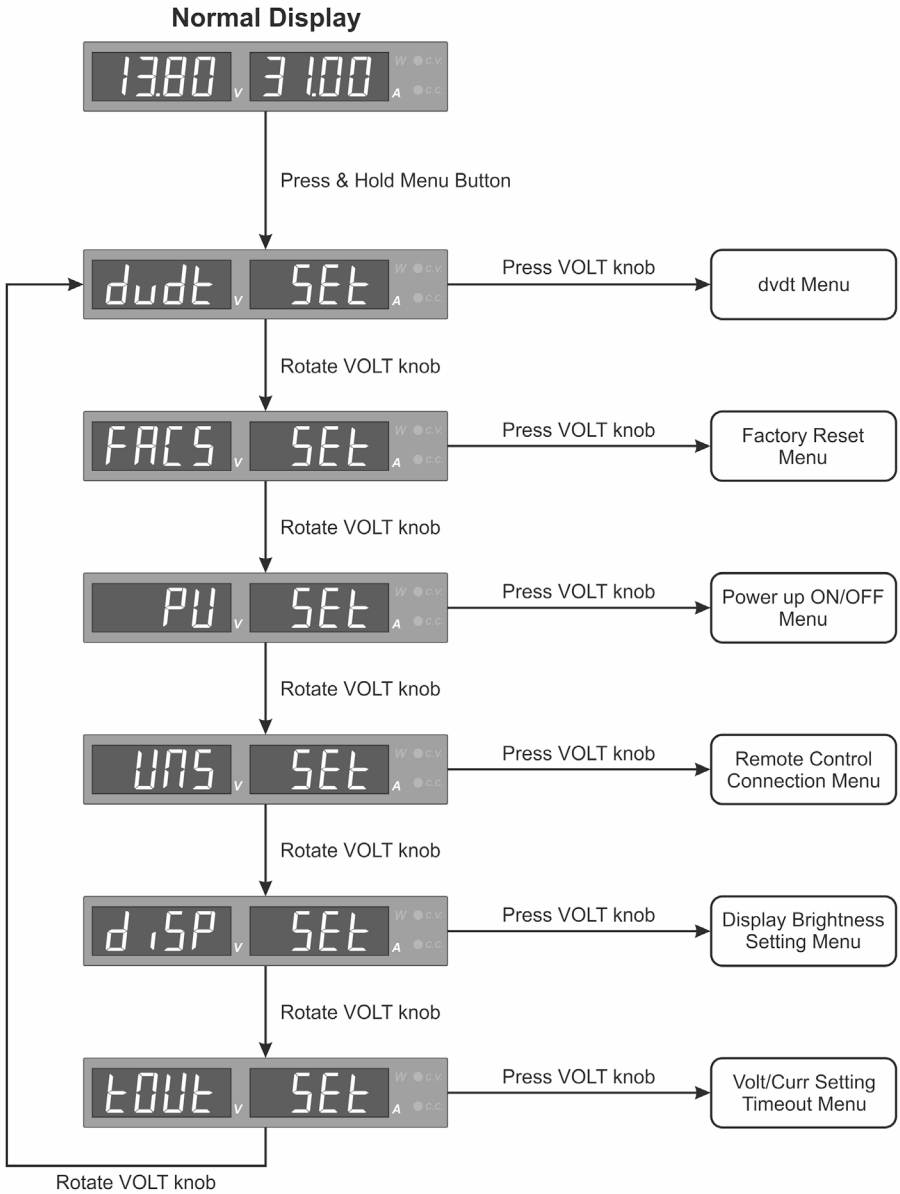

8. ANALOGUE REMOTE CONTROL MODE

There are two methods for remote control of current and voltage adjustment. Both methods require both the current and the voltage remote control to be set up together in order to make the remote control functional. The *output on-off* is optional and will not affect either voltage or current control.

Use the supplied 8 pin microphone plug for both method A and method B.

Remark: using the 8pin remote plug provided and connect with 22AWG wires.

8.1 Using the analogue remote control mode

Set the KPS power supply to Analogue Control Mode (AC) after all the connections with the 8-pin metal plug is inserted at port (5) at the rear panel.

1. Press and hold the [menu] button until display indicates setting menu mode.
2. Rotate the VOLT knob to [UNS] menu.



3. Press VOLT knob to enter into the UNS (Remote control interface selection).
4. Rotate CURR knob until [AC] (Analogue Control) shows up.

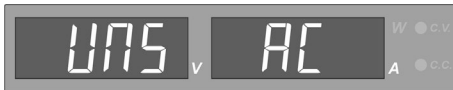

5. Press VOLT knob to confirm AC selection, the orange LED [REMOTE] lights up.



6. KPS power supply is in Analogue Remote Control Mode.
7. Press [menu] button to exit from setting mode. Take note of the Key Lock button (10) & Remote LED are ON.

8.2 To exit from the Analogue remote control mode

Press the [Lock/ Unlock] button (10) to exit from the Analogue Remote Control Mode. Take note of the orange [REMOTE] LED is OFF.

8.3 Method A

Using two external variable DC voltage sources.

Remote socket pin assignment for external variable voltage source.

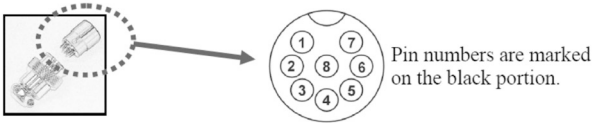

CC current setting by remote control.

Adjust the CC current using external power supply connected to Pin 3 and pin 4 (Ground).

Output voltage setting by remote control.

Check the output voltage range of the power supply by varying the external voltage source connected to Pin 2 and Pin 4 (Ground).

Remote socket pin assignment for external variable voltage source		
PIN	FUNCTION	REMARKS
1	Internal DC +5V	Less then 50mA
2	Voltage Adjust	0-5V
3	Current Adjust	0-5V
4	Ground	
5	Output OFF	Short to Ground
6	Fault signal for OVP, OTP	Output 5V/ 50mA max. for External alarm device
7	N.A.	
8	N.A.	

Remark:

Only connects to internal ground (pin 4) for all analog remote control functions. Don't connect to the unit output negative, otherwise it may damage the unit.

8.4 Method B

Use two 0 – 5K Ohm variable resistors Both variable resistors must be set up in order for the remote control to be functional.

CC current setting by remote control. Adjust the CC current setting using the 0-5k Ohm variable resistor. Similarly for the output voltage setting by adjusting the 5K ohm variable resistor.

Two variable resistors must be set up at the same time in order for the remote control to be functional

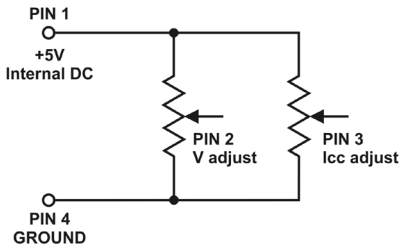

Remark: variable resistors 5Kohm.

Remote socket pin assignment for variable resistor		
PIN	FUNCTION	REMARKS
1	Internal DC +5V	Resistor end
2	Voltage Adjust	Variable part of resistor
3	Current Adjust	Variable part of resistor
4	Ground	Another resistor end
5	Output OFF	Short to Ground
6	Fault signal for OVP, OTP	Output 5V/ 50mA max. for External alarm device
7	N.A.	
8	N.A.	

Remark:

Only connects to internal ground (pin 4) for all analog remote control functions. Don't connect to the unit output negative, otherwise it may damage the unit.

8.5 Output ON/ OFF Remote Control

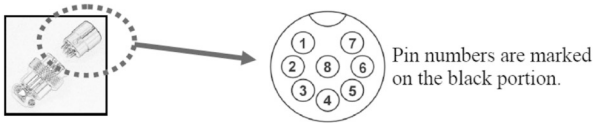

CAUTION !

The allowable fastest **output on-off** frequency is two cycles per second.

The power supply may **not** work normally when On-Off is over two cycles per second due to triggering of unit's protection system.

- A. By default, Pin 5 is in open circuit and output is on.
- B. Shorting Pin 5 to Pin 4 (ground) and output is off.
- C. When output is off the ammeter shows CC current setting value and the Output ON/ OFF Button [12] is lit off.
The current output voltage and current setting will show on the panel meter.
- D. You also can adjust the output by voltage & current control knob to your desired value when output is off.

8.6 Fault Signal Function

- A. Connects an external alarm device to Pin 6 (5V) and Pin 4 (Ground)
- B. The external alarm device can be an indicator like LED or buzzer but limited below 50mA.
- C. In case of unit over voltage protection (OVP) or over temperature protection (OTP), Pin 6 will output +5V signal for external alarm devices.